

# HIGH PERFORMANCE SEALS



**AFT Fluorotec**  
Incorporating SW Plastics



## Contents

<b>PTFE and Seal Materials</b>	<b>4</b>
<b>Spring Energiser Materials and Types</b>	<b>6</b>
– Spring Materials	
– V Springs	
– Canted Coil Springs	
– Helical Springs	
<b>Elastomer Energiser Materials</b>	<b>7</b>
<b>Part Numbering</b>	<b>8</b>
– Example	
<b>Reassurance at High Pressure</b>	<b>9</b>
– Back-up Rings	
– The Benefits of Back-up Rings	
– Plain PEEK Back-up Rings	
– Contoured PEEK Back-up Rings (O-ring Application)	
– Positively Actuated Back-up Rings	
<b>Special Applications</b>	<b>12</b>
<b>HPHT Valve Stem Seals</b>	<b>12</b>
<b>HPHT Gate Valve Seat Seals</b>	<b>13</b>
<b>Rod and Piston Seals</b>	<b>14</b>
<b>AFCB/AFCR</b>	<b>14</b>
<b>AFVB/AFVR</b>	<b>15</b>
<b>AFCCB/AFCCR</b>	<b>16</b>
<b>Face Seals</b>	<b>17</b>
<b>AFVI/AFVE</b>	<b>17</b>
<b>AFCI/AFCE</b>	<b>18</b>
<b>Double Acting Rod and Piston Seals</b>	<b>19</b>
<b>AFAB-R/AFAR-R</b>	<b>19</b>
<b>AFSB/AFSR</b>	<b>20</b>
<b>AFAB/AFAR</b>	<b>21</b>
<b>Single Acting Wiper</b>	<b>22</b>
<b>AFWR</b>	<b>22</b>
<b>AFVR-R</b>	<b>23</b>

## PTFE and Seal Materials

AFT Fluorotec have an extensive range of PTFE, Fluoropolymer and plastic materials manufactured within our UK base which gives complete control and flexibility to support almost any demand. Our range of PTFE materials and compounds extends to more than 300 variations of Virgin unfilled materials through standard filled compounds all the way to speciality blended materials to suit particular applications.

PTFE has many benefits making it ideal for sealing applications. Extremely high thermal stability, resistance to almost all chemicals, chemical inertness, Extremely low coefficient of friction (0.06), self lubricating properties, high melting point and the unique ability to resist thermal degradation. PTFE is an ideal material for use in dynamic sealing applications, even when running dry as it does not suffer any stick/slip effect. This low friction characteristic also makes it the ideal choice for high speed dynamic applications as heat build up through friction is minimal.

The addition of various fillers can alter some or all of these properties and can be adjusted to achieve desired physical properties to suit applications making our range of PTFE seals and materials extremely flexible.



<b>AF Code</b>	<b>Description</b>	<b>Application</b>
<b>AF001</b>	Virgin PTFE Temp range -220°C to +240°C Hardness 60 Shore D Tensile strength 30 MPa	Unfilled virgin PTFE. Chemically inert. Excellent cryogenic and gas performance. Poor creep resistance. FDA approved.
<b>AF617</b>	Modified PTFE Temp range -220°C to +270°C Hardness 60 Shore D Tensile strength 31 MPa	Virgin material with improved creep resistance (compressive strength) and lower gas permeability. Excellent cryogenic material and chemical resistance. FDA approved. Meets USP class VI.
<b>AF614 Ultimate</b>	Filled modified PTFE Temp range -220°C to +280°C Hardness 60 Shore D Tensile strength 29 MPa	Proprietary filled modified PTFE with increased compressive strength and creep resistance over AF617. Low deformation under load. FDA approved.
<b>AF202</b>	Carbon graphite filled PTFE Temp range -200°C to +270°C Hardness 67 Shore D Tensile strength >20 MPa	Excellent wear and creep resistance. Lower friction. Good for non lubricated applications.
<b>AF208</b>	Carbon fibre filled PTFE -120°C to +270°C Hardness 64 Shore D Tensile strength 34 MPa	Excellent wear and creep resistance. Good dynamic properties and improved flex and hardness. Great choice for extreme rotary applications and water service.
<b>AF103</b>	Glass fibre filled PTFE -120°C to +260°C Hardness 60 Shore D Tensile strength 31 MPa	Excellent compressive strength and reduced creep. Good wear resistance.
<b>AF106</b>	Glass fibre & mos <sup>2</sup> filled PTFE -120°C to +270°C Hardness 62 Shore D Tensile strength 31 MPa	Excellent high performance material with hardened running surfaces. High pressure and temperature and long wear life Molybdenum disulphide increases hardness while reducing friction.
<b>AF301</b>	Graphite filled PTFE -140°C to +270°C Hardness 59 Shore D Tensile strength 20 MPa	Low abrasion to soft shafts. Good for unlubricated service. Very low friction and good wear properties. Suitable for steam.
<b>AF401</b>	Bronze filled PTFE -120°C To +290°C Hardness 70 Shore D Tensile strength 18 MPa	Excellent extrusion resistance for high compressive loads. Long wearing and high temperature.
<b>AF410</b>	Bronze filled PTFE with additives -120°C to +290°C Hardness 69 Shore D Tensile strength >20 MPa	Increased wear and creep resistance over standard bronze filled PTFE.
<b>AF502</b>	Aromatic polyester filled PTFE -120°C +290°C Hardness 60 Shore D Tensile strength 30 MPa	Excellent high temperature performance and wear resistance. Very good for use against non hardened shafts. Not suitable for steam.
<b>AF640</b>	PTFE with special additives -180°C To +270°C Hardness 60 Shore D Tensile strength 42 MPa	Lower creep, excellent wear resistance and hardness, lower gas permeability.
<b>AF708</b>	PCTFE -260°C To +180°C Hardness 80 Shore D Tensile strength 40 MPa	Excellent chemical properties. Cryogenic and low temperature use. Request full data sheet for detailed properties across temperature range.
<b>AF777 GX</b>	UHMWPE with special additives -150°C To +120°C Hardness 60 Shore D Tensile strength 18 MPa	Extremely wear and abrasion resistant. Good lubricity in water. Good sliding properties. Excellent against highly abrasive media.

## Spring Energiser Materials and Types

Our spring energised seals range is supported with a variety of spring types and materials depending on the seal profile and application. We stock a comprehensive range of standard materials and profiles and have the ability to offer an extensive range of exotic options. Most materials can also be supplied with NACE approval.

### Spring Materials

**Stainless steel** – General purpose material for most applications. Very good corrosion resistance. Supplied in grade 301 or 302 as standard for most seals using a metallic spring. NACE approved and grades 304 and 316 available.

**Elgiloy®** – Cobalt-nickel-chromium-molybdenum alloy. Excellent corrosion resistant alloy with much greater mechanical strength properties over stainless steels which are retained at elevated temperatures. Widely used high performing alternative to stainless steel and can be supplied NACE approved. Additional heat treatment processes increase the strength and ductility of Elgiloy® springs.

**Hasteloy** – Alloy C-276. Excellent resistance to corrosion including hydrochloric and sulphuric acids, solvents and chlorine. Can be supplied with NACE approval.

### V Springs

V springs also referred to as cantilever, U or meander springs offer a light to medium load. This type of spring is intended for use in dynamic applications of rotary or linear motion and offers a relatively large amount of deflection. V springs are also used in static applications where large spring deflection is required i.e. a large tolerance on the groove dimensions, expansion/contraction/misalignment etc. Standard materials for V springs are stainless steel and Elgiloy®. V springs allow for an extremely flexible and wide operating range of seal. The load curve of a V spring is progressive until sudden failure and permanent deformation.

### Canted Coil Springs

Canted coil springs are made from a round wire coil that is formed so the coils lay over at an angle. This results in a load/deflection curve which is flat rather than progressive and very well suited to dynamic applications which are friction sensitive. Like the V spring, the canted coil spring is designed for use in dynamic applications of rotary and linear motion and static applications where a greater tolerance or deflection must be accommodated. Standard materials are stainless steel and Alloy C-276.

### Helical Springs

Helical springs are coil springs made from flat tape which is wound into a helix shaped coil. Helical springs offer a very limited amount of deflection versus a very high load displaying an instantly and dramatically progressive load/deflection curve. Helical springs are intended for use in static applications or in certain circumstances they can be used for very slow or infrequent dynamic applications providing higher friction is acceptable. Helical springs are ideal for high pressure or vacuum applications where precise tolerances can be adhered to on the groove detail. Helical springs should also be the first choice for cryogenic applications. For the most extreme service a double wall heat treated option can be supplied ensuring the maximum amount of sealing force and ductility of material at extreme cryogenic temperatures.

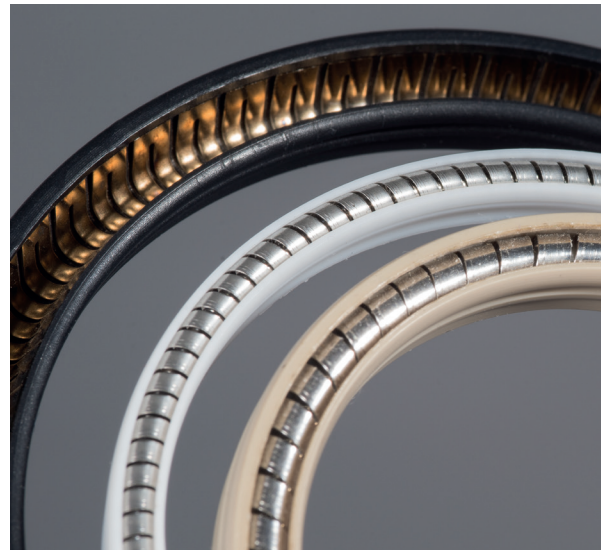

## Elastomer Energiser Materials

Material	Benefits/resistance to	Not recommended for
<b>NBR – Nitrile Rubber</b> Temperature range: -40°C to 120°C FDA grades available	<ul style="list-style-type: none"> <li>– Mineral based fluids</li> <li>– Petroleum oils and fluids</li> <li>– Diesel fuel and oils</li> <li>– Cold water</li> <li>– Silicone oil and grease</li> <li>– Mineral oil and grease</li> <li>– Vegetable oil</li> <li>– HFA, HFB and HFC fluids</li> </ul>	<ul style="list-style-type: none"> <li>– Aromatic hydrocarbons</li> <li>– Chlorinated hydrocarbons</li> <li>– Polar solvents (MEK, ketone, acetone)</li> <li>– Phosphate ester fluids</li> <li>– Strong acids</li> <li>– Automotive brake fluid</li> </ul>
<b>HNBR – Hydrogenated Nitrile Rubber</b> Temperature range: -40°C to 150°C FDA Grades available	<ul style="list-style-type: none"> <li>– Dilute acids and bases</li> <li>– Diesel fuels and fuel oil</li> </ul>	<ul style="list-style-type: none"> <li>– Aromatic hydrocarbons</li> <li>– Chlorinated hydrocarbons</li> <li>– Polar solvents (MEK, ketone, acetone)</li> <li>– Phosphate ester fluids</li> <li>– Strong acids</li> <li>– Automotive brake fluid</li> </ul>
<b>FPM (VITON®)</b> Temperature range: -20°C to 210°C FDA grades available	<ul style="list-style-type: none"> <li>– Petroleum oils and fluids</li> <li>– Cold water</li> <li>– Silicone oil and grease</li> <li>– Aliphatic hydrocarbons</li> <li>– Aromatic hydrocarbons</li> <li>– Fuels, including with methanol content</li> </ul>	<ul style="list-style-type: none"> <li>– Glycol based brake fluid</li> <li>– Superheated steam</li> <li>– Organic acids</li> <li>– Alkalis</li> <li>– Amines</li> <li>– Ammonia gas</li> </ul>
<b>FPM (VITON®) RGD Resistant</b> Temperature range: -30°C to 200°C Only available in Shore A 85	<ul style="list-style-type: none"> <li>– Petroleum oils and fluids</li> <li>– Cold water</li> <li>– Silicone oil and grease</li> <li>– Aliphatic hydrocarbons</li> <li>– Aromatic hydrocarbons</li> <li>– Fuels, including with methanol content</li> </ul>	<ul style="list-style-type: none"> <li>– Glycol based brake fluid</li> <li>– Superheated steam</li> <li>– Organic acids</li> <li>– Alkalis</li> <li>– Amines</li> <li>– Ammonia gas</li> </ul>
<b>EPDM – Ethylene Propylene Rubber</b> Temperature range: -55°C to 150°C FDA grades available	<ul style="list-style-type: none"> <li>– Hot water</li> <li>– Glycol based brake fluids</li> <li>– Many organic and inorganic acids</li> <li>– Cleaning fluids</li> <li>– Potassium and soda alkalis</li> <li>– Phosphate ester fluids</li> <li>– Most polar solvents</li> </ul>	<ul style="list-style-type: none"> <li>– Petroleum oils and fluids</li> <li>– Mineral oils and fluids</li> </ul>
<b>Silicone</b> Temperature range: -60°C to 230°C FDA grades available	<ul style="list-style-type: none"> <li>– High temperature air and oxygen</li> <li>– Hot water and steam</li> <li>– Alcohols</li> <li>– Excellent chemical resistance</li> <li>– Non toxic</li> <li>– Ozone</li> </ul>	<ul style="list-style-type: none"> <li>– Poor abrasion and tensile strength</li> </ul>

## Part Numbering

AFT Fluorotec range of spring and rubber energised seals are identified by a part numbering system as follows:

### Example

AFAB - 01000 - 0250 - 0850 - 201

AFAB Specifies the seal section type \_\_\_\_\_

Groove nominal diameter \_\_\_\_\_  
01000 equals 10.00mm.

For bore seals the 10mm refers to the diameter of the bore.  
For rod seals the 10mm refers to the diameter of the rod.

Groove cross section \_\_\_\_\_  
0250 equals 2.5mm

Groove width \_\_\_\_\_  
0850 equals 8.5mm

AF material code for seal jacket \_\_\_\_\_

Energiser material is stated in full due to the variety of options.

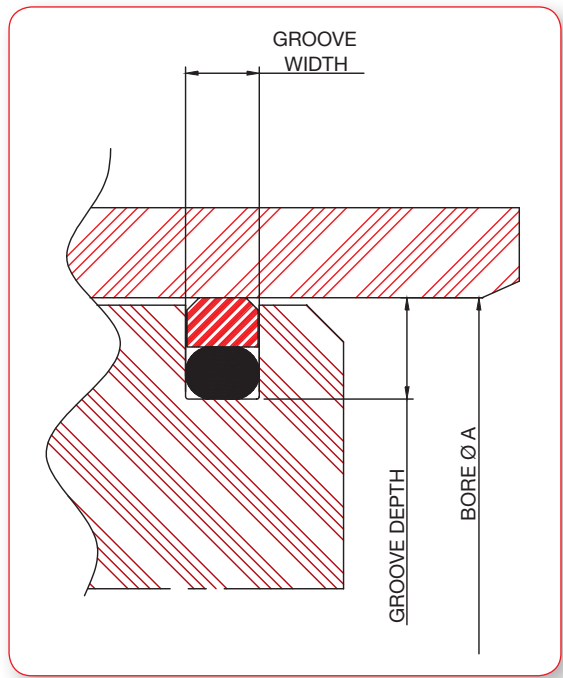

Face seal part numbering is similar with the nominal diameter always referring to the diameter of the heel of the seal. See individual face seal pages for more information.



## Reassurance at High Pressure

### Back-up Rings

Seal functionality and performance is very much reliant on the correct design of the grooves in which they are located. Often the clearance required for machining and assembly of the metalwork components means the extrusion gap (the difference between the diameters of the machined parts – piston and bore – sitting behind the seal) can lead to the PTFE extruding under pressure into this gap and the seal failing. This becomes a major factor when dealing with high pressures combined with high temperatures. There are a variety of solutions to combat this. Modified or extended seal ‘heel’ configuration is the simplest solution, however at higher temperatures and pressures, Back-up rings become the best solution.

### The Benefits of Back-up Rings

Back-up rings provide additional extrusion resistance and prevent damage to O-rings and seals. Back-up rings can be used in all applications but primarily are added when higher pressures or pressure spikes, higher temperatures and/or larger extrusion gaps form part of the operating conditions. Higher temperatures generally lower a seals extrusion resistance. Installing a PEEK back-up ring can normally combat this.

Back-up rings are not seals themselves, but are used in conjunction with seals and O-rings in high-pressure applications. Back-up rings are installed in the downstream side of the gland, however can be installed either side of an O-ring to give a high performance double acting seal. Back-up rings can be added to most seal applications, commonly profile types AFVR, AFVB, AFVR, AFVR, AFVR, AFVR, AFVR, AFVR, AFVR and AFVR. This can be in the format of a single plain flat Back up ring or a complex positively actuated single or double back up ring configuration for the most demanding service.



### Plain PEEK Back-up Rings

- Flat-faced rectangular section rings similar to washers
- These are dimensioned to neatly fit the radial cross section of the seal groove
- Length (thickness) can be to BS or ASTM standards or specified to suit any application (O-ring application)
- Can be supplied as solid rings or with a scarf cut to allow easy installation in closed grooves

### Contoured PEEK Back-up Rings (O-ring Application)

- A step up in performance over plain PEEK back-up rings
- Designed with a concave or contoured face on one side and a flat face on the other
- The contoured face comes in contact with the O-ring and provides better grip and support than a standard flat option.
- Length (thickness) can be to BS or ASTM standards or specified to suit any application
- Can be supplied as solid rings or with a scarf cut to allow easy installation into closed grooves
- Recommended for reciprocating applications

### Positively Actuated Back-up Rings

- Automatically forced (actuated) by the system pressure both axially and radially to blank the extrusion gap
- Can be integrated into a seal design or they can be specially shaped individual items
- Often in the form of two individual rings, which work against each other to completely eliminate any gap
- Can be supplied as a solid rings or with a scarf cut to allow installation into closed grooves

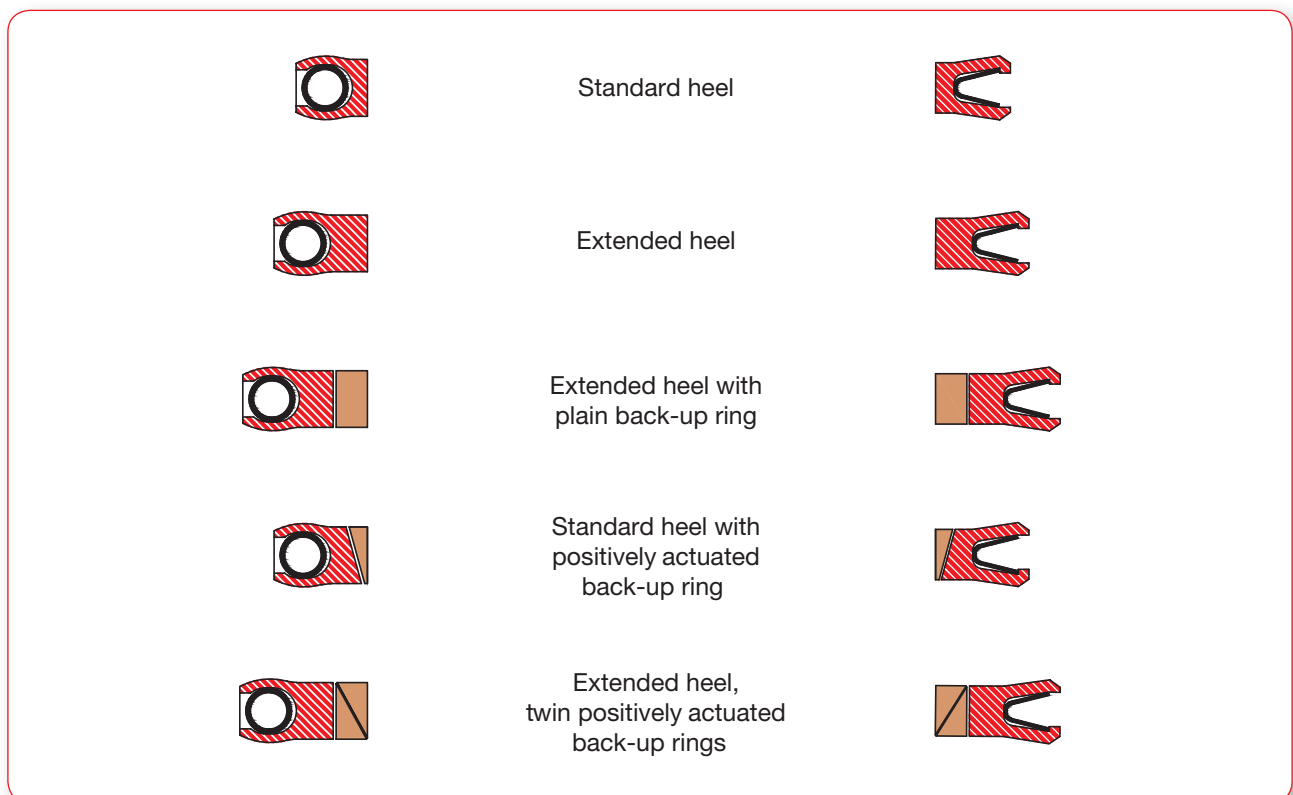



## Special Applications

Every seal manufactured at AFT Fluorotec is designed and made specifically to suit the application. Whilst we work around typical designs and groove dimensions for much of what we do, it is not a full picture of all we do. Many of the seals we design and supply are specials – the difficult applications, the extremes, often specific to particular products and service conditions and very often oil and gas related.

### HPHT Valve Stem Seals

AFT manufacture a wide variety of high pressure high temperature high performance valve stem seal assemblies and gland packings. None of these are standard although many follow a standard theme. Featured here is an example of a high pressure gate valve stem seal assembly, tested at 15000 PSI and -29°C to +180°C.

These products are extremely versatile and somewhat modular. The V-ring can be made in PEEK, filled PTFE or even an elastomer for certain applications. They can be designed with more than one V-ring in each stack and they don't have to be the same material to improve lower and higher temperature performance.

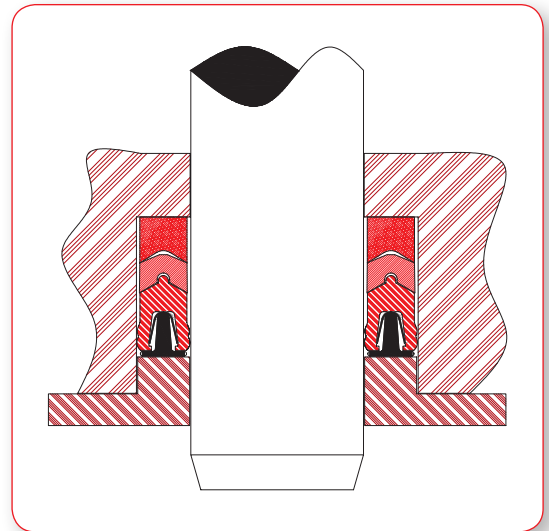

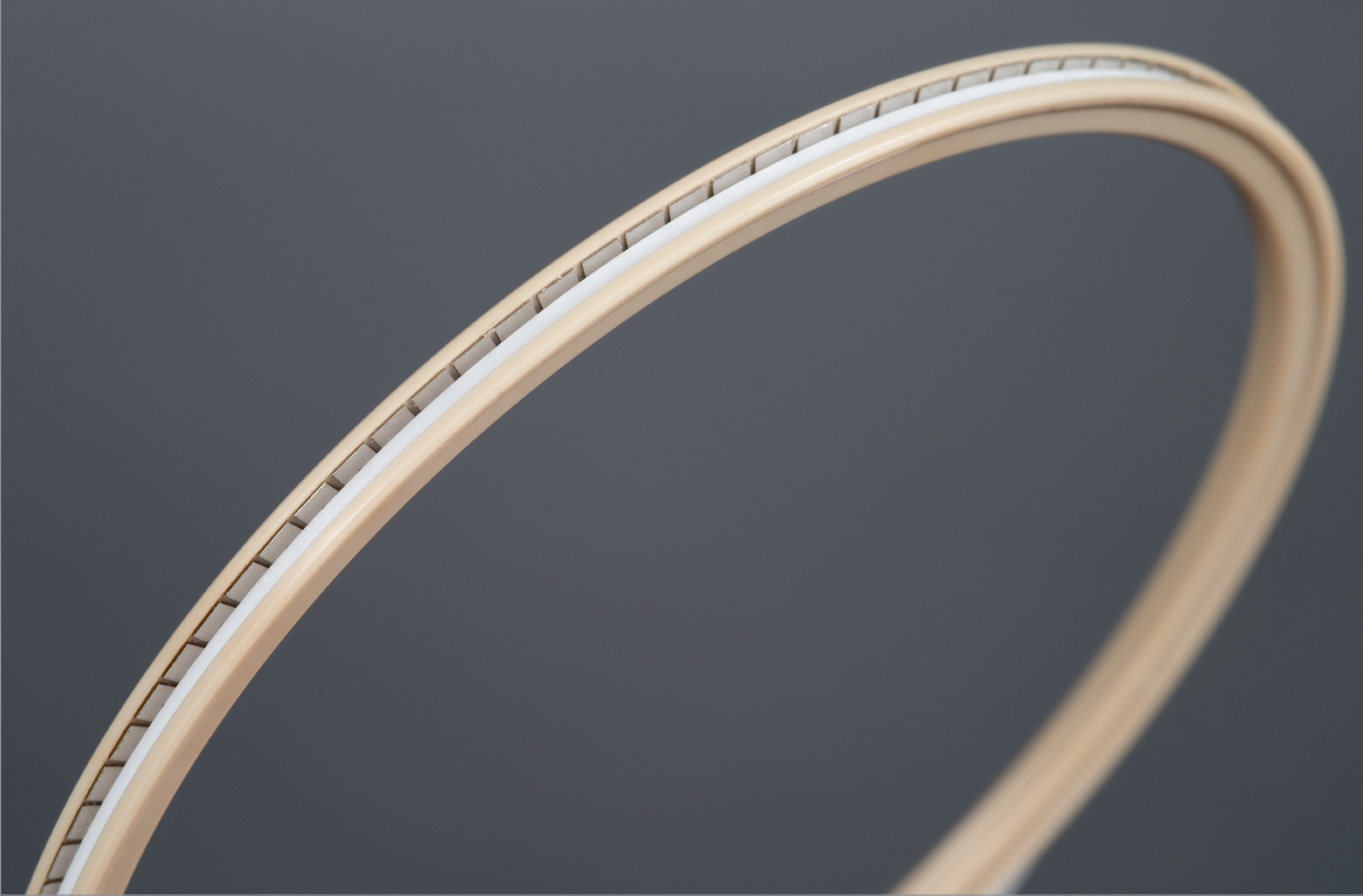

## HPHT Gate Valve Seat Seals

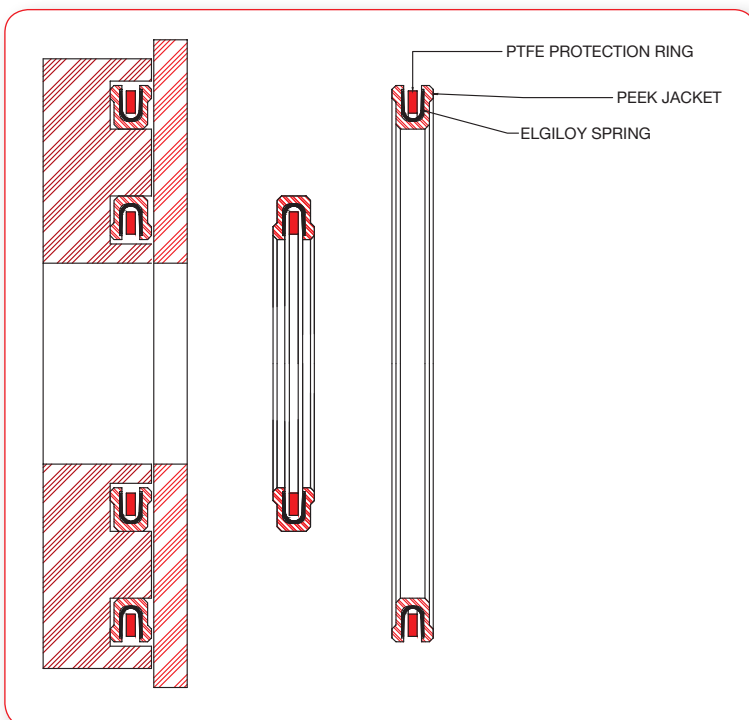

All of our spring energised rod and piston seals are available as face seals however certain extreme applications require extreme seals.

AFT design and manufacture HPHT gate valve seat seals for valve manufacturers worldwide. Typically these comprise an AF801 Victrex™ PEEK jacket energised with an Elgiloy® spring with a PTFE insert to prevent permanent deformation of the seal and spring should something go wrong. This means that even after an episode of rapid decompression, the seals will perform as normal.

These high performance face seals are not limited to gate valves. They can be used in any extreme applications where a high performance semi static seal is required.

# Rod and Piston Seals



## AFCB/AFCR

Radial rod and piston seals for static and dynamic applications. Typically energised with a Helical tape wound spring but also very effective with an O-ring energiser. Spring pre-load is fairly high which gives an increase in seal friction but also very positive sealing. Generally used for high pressure applications. The heel length of this type of seal can be increased for higher pressure applications and these can be combined with Back-up rings as shown on page 9.

- Excellent static sealing
- High spring preload
- Higher seal friction
- Limited to open grooves except in large diameters
- Available up to 1850mm diameter
- Any groove depth and width can be accommodated with bespoke profiles
- Pressure up to 70 MPa/700 bar (Additional Back-up rings may allow more)
- Operating temperature -196°C to +260°C

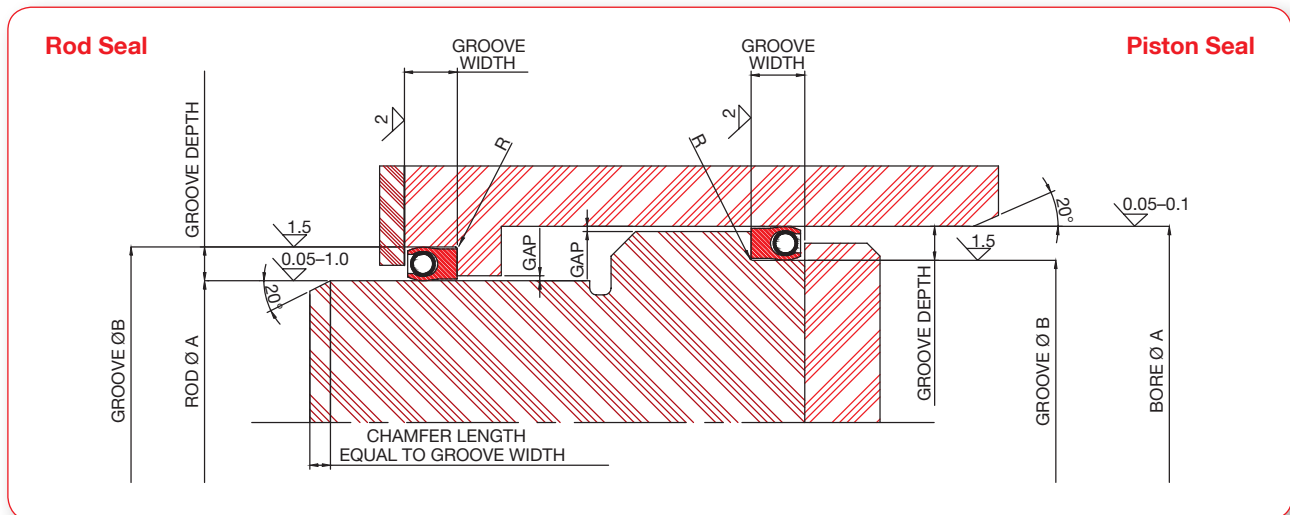

## AFCB/AFCR

Nominal Diameter	Groove Depth	Groove Width Standard	Groove Width Extended	Max Gap (Radial Clearance)	R Max
10-20mm	2.26/2.31	3.60	4.60	0.12	0.4
20-40mm	3.07/3.12	4.80	6.00	0.14	0.4
40-120mm	4.67/4.73	7.10	8.50	0.16	0.6
120-500mm	6.07/6.13	9.50	12.10	0.20	0.6
500-1200mm	9.35/9.40	13.50	15.00	0.22	0.8



## AFVB/AFVR

Radial rod and piston seals for static and dynamic applications. Typically energised with a V (cantilever) or canted coil spring. Spring pre-load is light to medium which keeps friction lower. High seal deflection can be tolerated without permanent deformation. The heel length of this type of seal can be increased for higher pressure applications and these can also be combined with Back-up rings as shown on page 9 for higher pressure applications. Often used in Valve stems for high pressure slow rotary dynamic applications or linear reciprocating seals up to 15m/s.

- Excellent dynamic sealing particularly in reciprocating applications up to 15m/s
- Lower seal friction
- Limited to open grooves except in large diameters
- Available up to 1850mm diameter
- Any groove depth and width can be accommodated with bespoke profiles
- Pressure up to 45 MPa/450 bar
- Surface speeds up to 15 M/S
- Operating temperature -80°C to +260°C

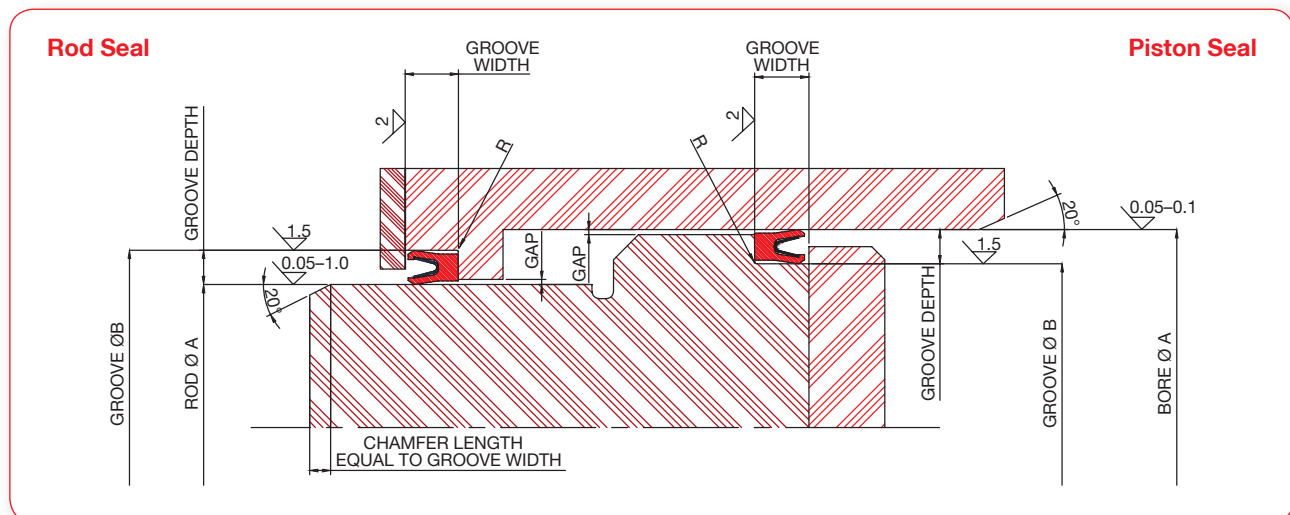

## AFVB/AFVR

Nominal Diameter	Groove Depth	Groove Width Standard	Groove Width Extended	Max Gap (Radial Clearance)	R Max
10-20mm	2.26/2.31	3.60	4.60	0.12	0.4
20-40mm	3.07/3.12	4.80	6.00	0.14	0.4
40-120mm	4.67/4.73	7.10	8.50	0.16	0.6
120-500mm	6.07/6.13	9.50	12.10	0.20	0.6
500-1200mm	9.35/9.40	13.50	15.00	0.22	0.8



## AFCCB/AFCCR

Radial rod and piston seals for static and dynamic applications. Energised with a canted coil spring. Spring pre-load is light to medium which keeps friction lower and allows the seals to cope with slight misalignment. High seal deflection can be tolerated without permanent deformation. Permanent deformation is defened by the canted coil spring in full compression acting as a solid stop. The heel length of this type of seal, similar to others, can be increased for higher pressure applications and these can also be combined with any combination of back up rings as shown on page 9 for higher pressure applications. Often used in valve stems for high pressure slow rotary dynamic applications or linear reciprocating seals up to 15m/s. Canted coil spring gives a constant energiser pressure regardless of level of pre-load compression

- Excellent Dynamic sealing particularly in reciprocation applications up to 15m/s
- Lower seal friction
- Limited to open grooves except in large diameters
- Available up to 1850mm diameter
- Any groove depth and width can be accommodated with bespoke profiles
- Pressure up to 45 MPa/450 bar
- Surface speeds up to 15m/s
- Operating temperature -80°C to + 260°C

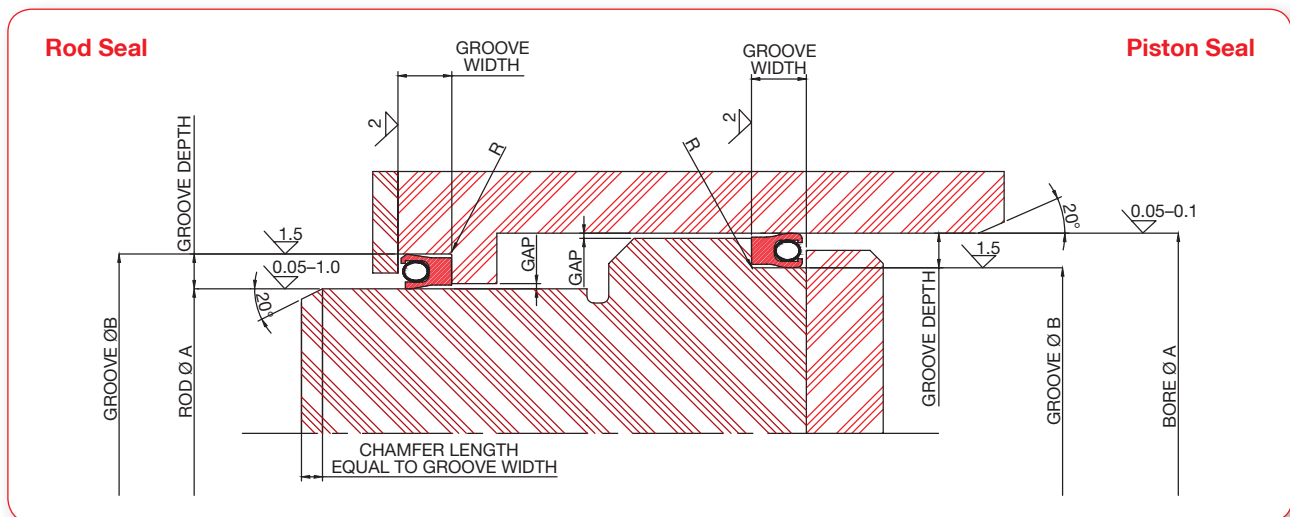

## AFCCB/AFCCR

Nominal Diameter	Groove Depth	Groove Width Standard	Groove Width Extended	Max Gap (Radial Clearance)	R Max
10–20mm	2.26/2.31	3.60	4.60	0.12	0.4
20–40mm	3.07/3.12	4.80	6.00	0.14	0.4
40–120mm	4.67/4.73	7.10	8.50	0.16	0.6
120–500mm	6.07/6.13	9.50	12.10	0.20	0.6
500–1200mm	9.35/9.40	13.50	15.00	0.22	0.8

Examples shown feature contoured profile for easier assembly and also a scraper lip which is specific to reciprocating. These are available across the whole range of energised seals to suit individual requirements



# Face Seals



## AFVI/AFVE

Internal and external face seals energized with a V (cantilever) spring are suitable for static and slow dynamic applications. Spring pre-load is light to medium which keeps friction lower. Some seal deflection can be tolerated without permanent deformation as the V spring allows the seal to cope with minor misalignment. The heel length of this type of seal can be increased for high pressure applications and these can also be combined with back up rings as shown on page 9 for higher pressure applications.

- Good general purpose face seal
- Low seal friction
- Available up to 1850mm diameter
- Any groove depth and width can be accommodated with bespoke profiles
- Pressure up to 50 MPa / 500 bar (this can be increased with back up rings to 2000 bar)
- Operating temperature -80°C to + 260°C

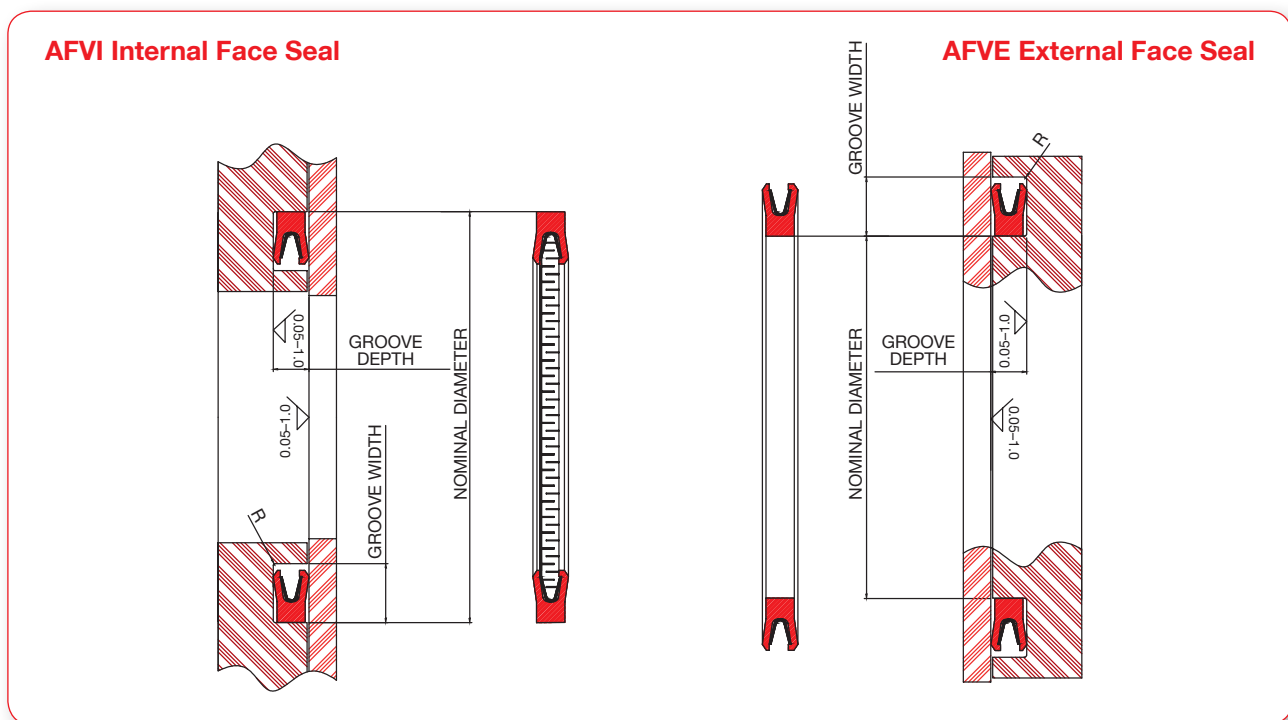

## AFVI/AFVE

Nominal Diameter	Groove Depth	Groove Width Standard	Groove Width Extended	Max Gap (Radial Clearance)	R Max
10-20mm	2.26/2.31	3.60	4.60	0.12	0.4
20-40mm	3.07/3.12	4.80	6.00	0.14	0.4
40-120mm	4.67/4.73	7.10	8.50	0.16	0.6
120-500mm	6.07/6.13	9.50	12.10	0.20	0.6
500-1200mm	9.35/9.40	13.50	15.00	0.22	0.8



## AFCI/AFCE

Internal and external face seals energized with a tape wound helical spring suitable for static applications only. Spring pre-load is high and these type of seals require precision in the two mating faces. The heel length of this type of seal can be increased to accommodate higher pressures and this seal profile type can also be combined with back up rings as shown on page 9 for even higher pressure applications

- Primary choice for high load/tight sealing
- High spring preload
- Available up to 1850mm diameter
- Any groove depth and width can be accommodated with bespoke profiles
- Pressure up to 50 MPa/500 bar (this can be increased with back up rings to 2000 bar)
- Operating temperature -80°C to + 260°C

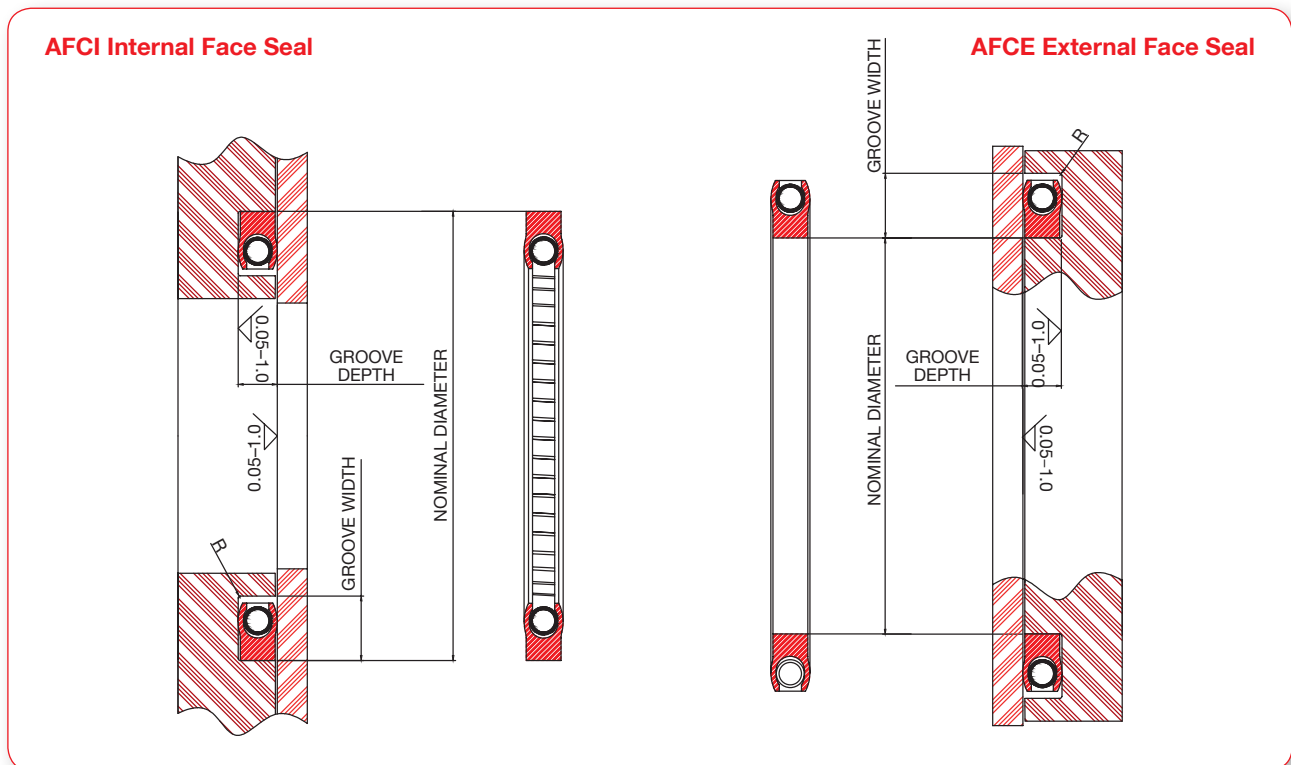

## AFCI/AFCE

Nominal Diameter	Groove Depth	Groove Width Standard	Groove Width Extended	Max Gap (Radial Clearance)	R Max
10-20mm	2.26/2.31	3.60	4.60	0.12	0.4
20-40mm	3.07/3.12	4.80	6.00	0.14	0.4
40-120mm	4.67/4.73	7.10	8.50	0.16	0.6
120-500mm	6.07/6.13	9.50	12.10	0.20	0.6
500-1200mm	9.34/9.40	13.50	15.00	0.22	0.8

# Double Acting Rod and Piston Seals

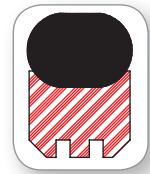

## AFAB-R/AFAR-R

BI-directional piston and rod seals for rotary applications. The simplicity of the seals keeps costs low and offers designers a large choice of sealing materials.

- Excellent low friction
- Extremely robust
- No Stick/slip effect during start up
- Can be used in dry and lubricated media
- Simple compact groove design
- Available up to 1850mm diameter
- Any groove depth can be accommodated with bespoke profiles
- Pressure up to 30 MPa/300 bar
- Intermittent oscillatory up to 5m/s.
- Continuous rotation up to 1m/s
- Operating temperature -60°C to +220°C determined by O-ring material

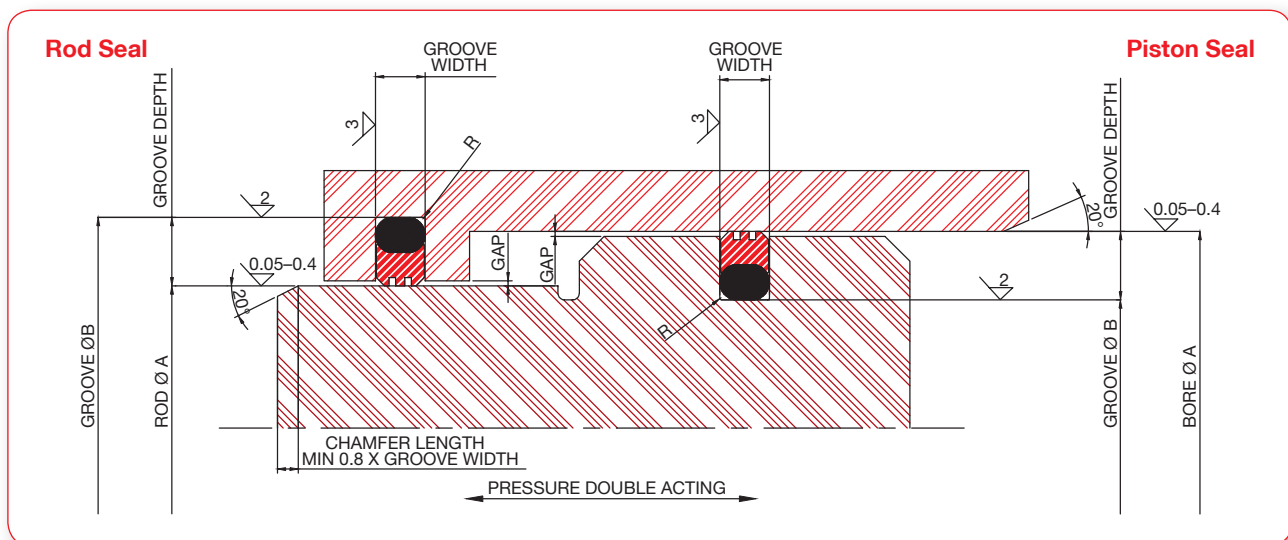

### AFAB-R

Rod Øa	Groove Depth	Groove Width	Max Gap (Radial Clearance)		R Max	O Ring C/S
			Up To 15 Mpa (150 Bar)	15-30 Mpa (150-300 Bar)		
8-40	2.45	2.2/2.4	0.12-0.2	0.07-0.12	0.4	1.78
40.1-80	3.75	3.2/3.4	0.20-0.3	0.10-0.20	0.6	2.62
80.1-133	5.50	4.2/4.4	0.20-0.3	0.10-0.20	1.0	3.53
133.1-330	7.75	6.3/6.5	0.25-0.4	0.15-0.25	1.3	5.33
330.1-670	10.50	8.1/8.3	0.25-0.4	0.15-0.25	1.7	7.00
670.1-1000	14.00	9.5/9.7	0.45-0.6	0.25-0.40	2.4	8.40

O-ring inside diameter should be equal to or less than groove ØB.

### AFAR-R

Rod Øa	Groove Depth	Groove Width	Max Gap (Radial Clearance)		R Max	O Ring C/S
			Up To 15 Mpa (150 Bar)	15-30 Mpa (150-300 Bar)		
8-19.0	2.45	2.2/2.4	0.12-0.2	0.07-0.12	0.4	1.78
19.1-38	3.75	3.2/3.4	0.20-0.3	0.10-0.20	0.6	2.62
38.1-200	5.50	4.2/4.4	0.20-0.3	0.10-0.20	1.0	3.53
200.1-256	7.75	6.3/6.5	0.25-0.4	0.15-0.25	1.3	5.33
256.1-650	10.50	8.1/8.3	0.25-0.4	0.15-0.25	1.7	7.00
650.1-1000	14.00	9.5/9.7	0.45-0.6	0.25-0.40	2.4	8.40

O-ring outside diameter should be equal to or greater than groove ØB.



## AFSB/AFSR

Single acting universal and well proven rod and piston seals for hydraulic and pneumatic cylinders and a host of general engineering applications. Available, but not limited to six standard cross sections, the AFAB/R seals feature a profile which keeps friction to a minimum and also provides an excellent wiper.

- Excellent low friction
- No start up stick/slip effect
- Can be used in dry and lubricated media
- Simple compact groove design
- Available up to 1850mm diameter
- Any groove depth can be accommodated with bespoke profiles
- Pressure up to 40 MPa/400 bar at 5m/s
- Operating temperature -60°C to +220°C determined by O-ring material

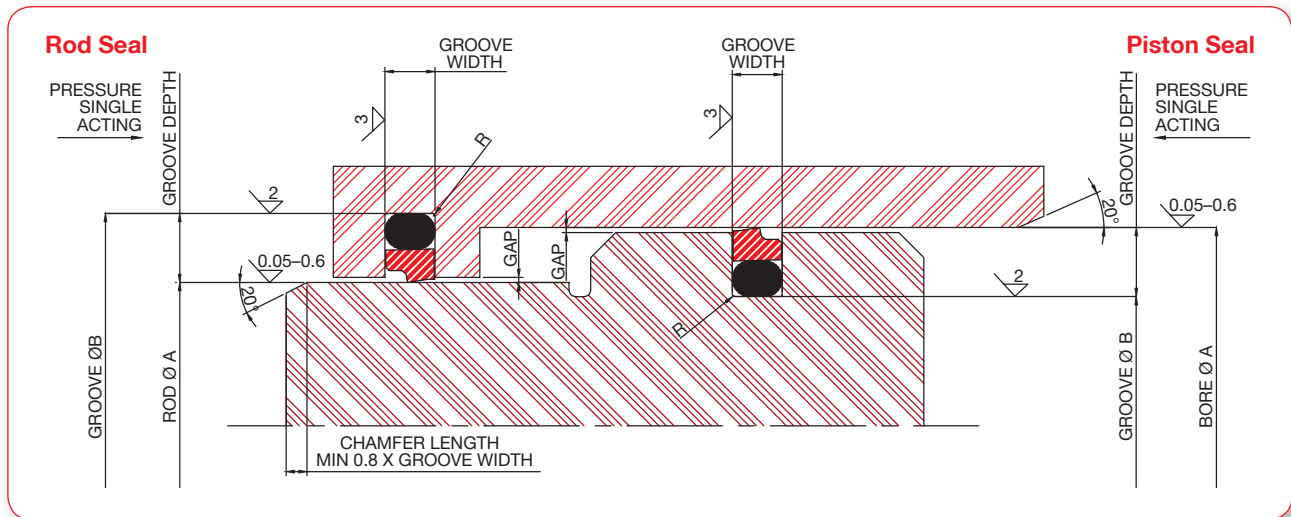

### AFSB

Bore Øa Light Duty	Bore Øa Medium Duty	Bore Øa Heavy Duty	Groove Depth	Groove Width	Max Gap (Radial Clearance)		R	O-ring C/S
					Up To 20 Mpa (200 Bar)	20–40 Mpa (200–400 Bar)		
15–40			2.45	2.2/2.4	0.2–0.3	0.15–0.2	0.4	1.78
40.1–80	15–40		3.65	3.2/3.4	0.25–0.4	0.15–0.25	0.6	2.62
80.1–133	40.1–80	15–40	5.35	4.2/4.4	0.25–0.5	0.2–0.25	1.0	3.53
133.1–330	80.1–133	40.1–80	7.55	6.3/6.5	0.3–0.5	0.2–0.3	1.3	5.33
330.1–670	133.1–330	80.1–133	10.25	8.1/8.3	0.3–0.5	0.25–0.3	1.7	7.00
670.1–1000	330.1–670	133.1–330	12.00	8.1/8.3	0.5–0.6	0.3–0.4	1.7	7.00
	670.1–1000	330.1–670	13.65	9.5/9.7	0.5–0.7	0.35–0.5	2.4	8.40

O-ring inside diameter should be equal to or less than groove ØB.

### AFSR

Rod Ø A Light Duty	Rod Øa Medium Duty	Rod Øa Heavy Duty	Groove Depth	Groove Width	Max Gap (Radial Clearance)		R	O-ring C/S
					Up To 20 Mpa (200 Bar)	20–40 Mpa (200–400 Bar)		
8–19.0			2.45	2.2/2.4	0.2–0.3	0.15–0.2	0.4	1.78
19.1–38	8–19.0		3.65	3.2/3.4	0.25–0.4	0.15–0.25	0.6	2.62
38.1–200	19.1–38	8–19.0	5.35	4.2/4.4	0.25–0.5	0.2–0.25	1.0	3.53
200.1–256	38.1–200	19.1–38	7.55	6.3/6.5	0.3–0.5	0.2–0.3	1.3	5.33
256.1–650	200.1–256	38.1–200	10.25	8.1/8.3	0.3–0.5	0.25–0.3	1.7	7.00
650.1–1000	256.1–650	200.1–256	12.00	8.1/8.3	0.5–0.6	0.3–0.4	1.7	7.00
	650.1–1000	256.1–650	13.65	9.5/9.7	0.5–0.7	0.35–0.5	2.4	8.40

O-ring outside diameter should be equal to or greater than groove ØB.



## AFAB/AFAR

Medium duty well proven bi-directional piston and rod seals. Typically used in pneumatic and hydraulic cylinder applications and general engineering. The simplicity of the seals keeps costs low and offers designers a large choice of sealing materials.

- Excellent low friction
- Extremely robust
- Can be used in dry and lubricated media
- Simple compact groove design
- Available up to 1850mm diameter
- Any groove depth can be accommodated with bespoke profiles
- Pressure up to 40 MPa/400 bar at 5m/s
- Up to 750 bar in static applications
- Operating temperature -60°C to +220°C determined by O-ring material

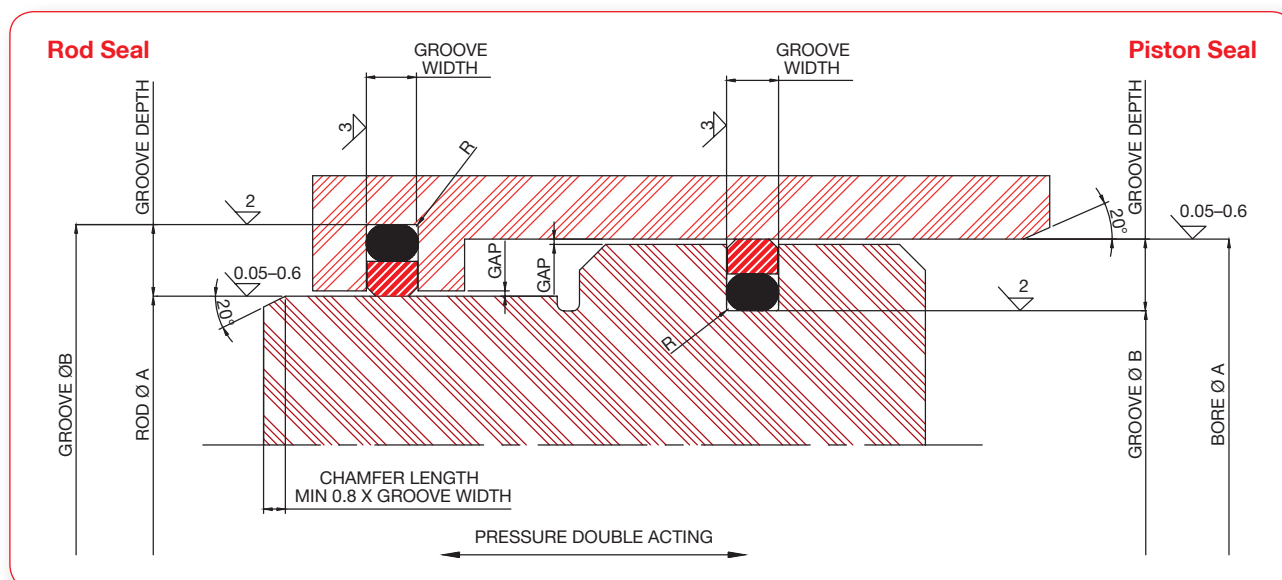

### AFAR

Rod Ø A Light Duty	Rod Øa Medium Duty	Rod Øa Heavy Duty	Groove Depth	Groove Width	Max Gap (Radial Clearance)		R	O-ring C/S
					Up To 20 Mpa (200 Bar)	20–40 Mpa (200–400 Bar)		
8–19			2.45	2.2/2.4	0.2–0.3	0.15–0.2	0.4	1.78
19.1–38	8–19		3.65	3.2/3.4	0.25–0.4	0.15–0.25	0.6	2.62
38.1–200	19.1–38	8–19	5.35	4.2/4.4	0.25–0.5	0.2–0.25	1.0	3.53
200.1–256	38.1–200	19.1–38	7.55	6.3/6.5	0.3–0.5	0.2–0.3	1.3	5.33
256.1–650	200.1–256	38.1–200	10.25	8.1/8.3	0.3–0.5	0.25–0.3	1.7	7.00
650.1–1000	256.1–650	200.1–256	12.00	8.1/8.3	0.5–0.6	0.3–0.4	1.7	7.00
	650.1–1000	256.1–650	13.65	9.5/9.7	0.5–0.7	0.35–0.5	2.4	8.40

O-ring outside diameter should be equal to or greater than groove ØB.

### AFAB

Bore Øa Light Duty	Bore Øa Medium Duty	Bore Øa Heavy Duty	Groove Depth	Groove Width	Max Gap (Radial Clearance)		R	O-ring C/S
					Up To 20 Mpa (200 Bar)	20–40 Mpa (200–400 Bar)		
15–40			2.45	2.2/2.4	0.25–0.4	0.15–0.25	0.6	2.62
40.1–80	15–40		3.75	3.2/3.4	0.25–0.5	0.2–0.25	1.0	3.53
80.1–133	40.1–80	15–40	5.50	4.2/4.4	0.3–0.5	0.2–0.3	1.3	5.33
133.1–330	80.1–133	40.1–80	7.75	6.3/6.5	0.3–0.5	0.25–0.3	1.7	7.00
330.1–670	133.1–330	80.1–133	10.5	8.1/8.3	0.5–0.6	0.3–0.4	1.7	7.00
670.1–1000	330.1–670	133.1–330	12.25	8.1/8.3	0.5–0.7	0.35–0.5	2.4	8.40
	670.1–1000	330.1–670	14.00	9.5/9.7				

O-ring inside diameter should be equal to or less than groove ØB.

# Single Acting Wipers



## AFWR

Single lip PTFE wiper seal designed for reciprocating shafts to prevent ingress of unwanted media, dust and water. The secondary lip at the heel keeps the seal in balance and acts to wipe oil away from the shaft before it passes through the wiper lip.

- Very good external wiping even against well adhered media
- Good internal wiping of oil
- No stick/slip effect during start up
- Low friction
- Can be used in dry and lubricated media
- Simple compact groove design
- Available up to 1850mm diameter
- Any groove depth and width can be accommodated with bespoke profiles
- Reciprocating up to 15m/s
- Operating temperature -60°C to +200°C determined by O-ring material

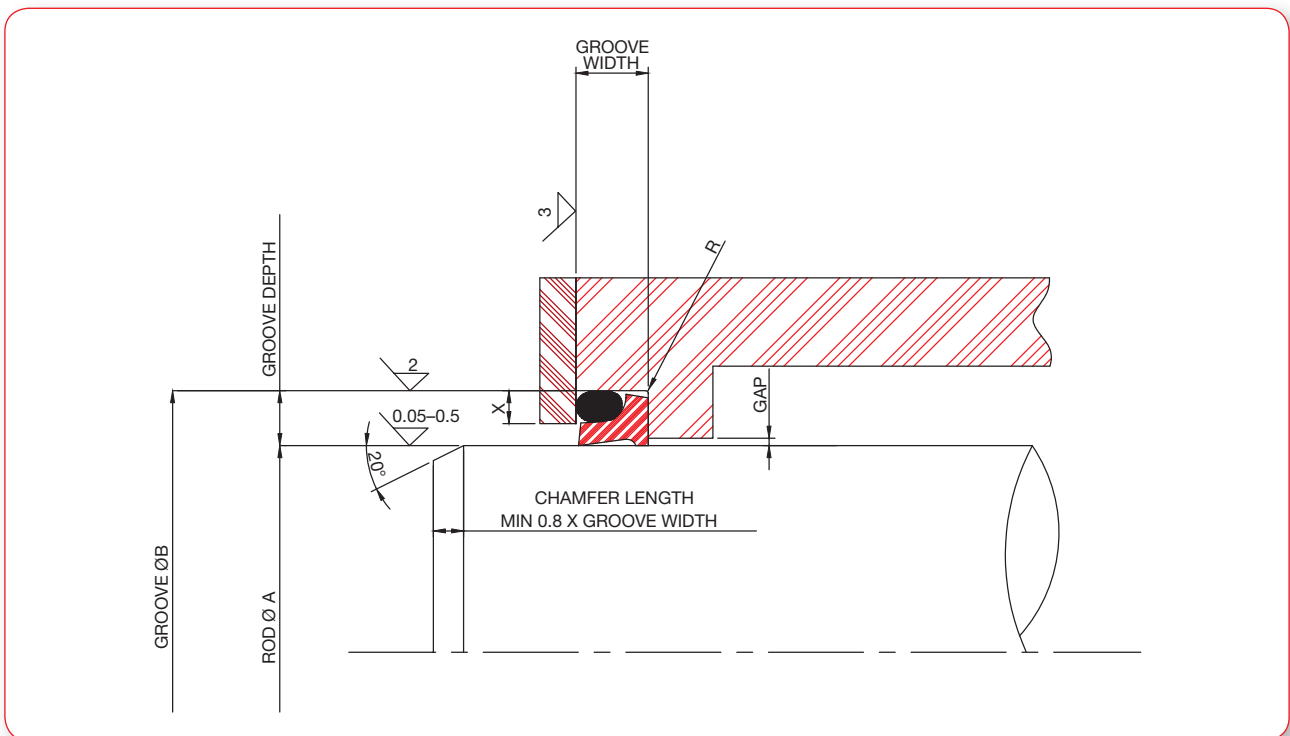

## AFWR

Rod ØA	Groove Depth	Groove Width	Max Gap (Radial Clearance)	X Min	R Max	O Ring C/S
5-12	2.45	4.0/4.2	0.90	1.7	0.4	1.78
19.1-38	3.75	3.2/3.4	1.40	2.4	0.6	2.62
38.1-200	5.50	4.2/4.4	1.60	3.2	1.0	3.53
200.1-256	7.75	6.3/6.5	1.90	4.5	1.2	5.33
256.1-650	10.50	8.1/8.3	2.40	5.5	1.4	7.00
650.1-1000	14.00	9.5/9.7	2.90	6.0	1.9	8.40

O-ring outside diameter should be approximately equal to or greater than groove ØB.

# Rotary Shaft Seals



## AFVR-R

Rotary shaft seal energized with a V (cantilever) or canted coil spring for single acting rotary applications. These seals are very well suited to small diameters where groove size is restricted.

- Rotary applications up to 15m/s
- Low seal friction
- Flange clamping controls rotation
- Available up to 1850mm diameter
- Any groove depth and width can be accommodated with bespoke profiles
- Maximum pressure is dependant on surface speed
- Surface speeds up to 15m/s
- Operating temperature -80°C to + 200°C

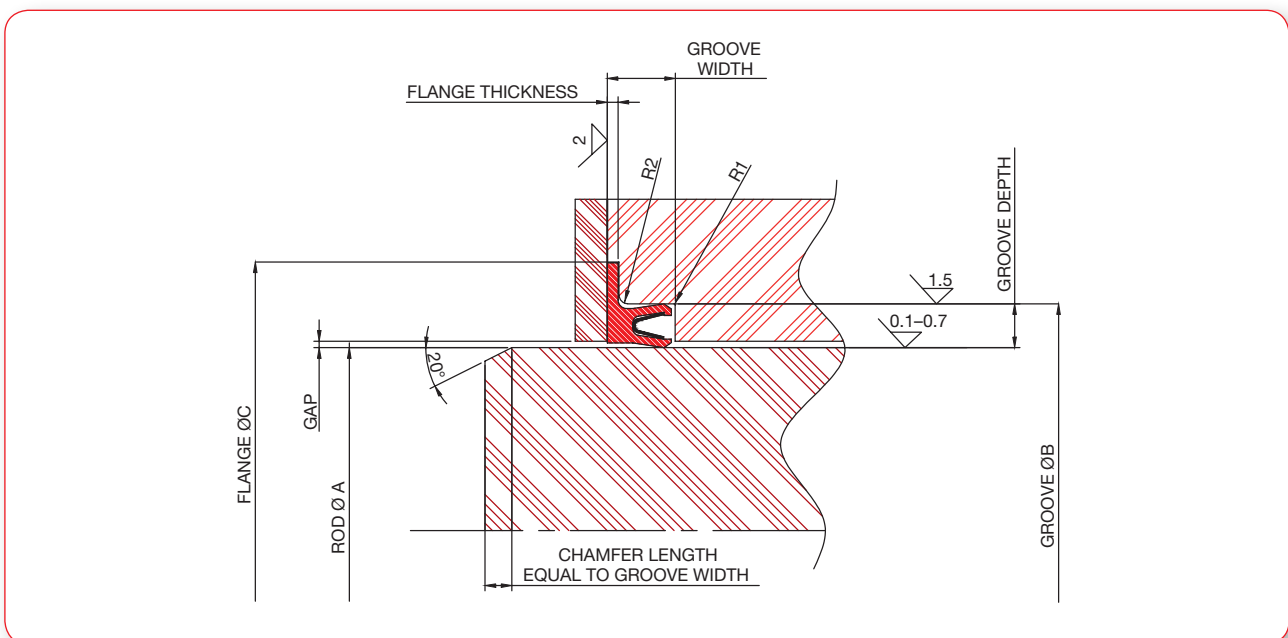

## AFVR-R

Nominal diameter	Groove Depth	Groove Width Standard	R1 (Max)	R2 (Min)	Max Gap (Radial Clearance)	ØC (Min)	Flange Thickness
10-20	2.26/2.31	3.6	0.4	0.0.9	0.12	Rod ØA + 13	0.75
20-40	3.07/3.12	4.8	0.6	1	0.14	Rod ØA + 14	1
40-120	4.67/4.73	7.1	0.8	1.3	0.16	Rod ØA + 20	1.5
120-1000	6.07/6.13	9.5	0.8	1.5	0.2	Rod ØA + 22	2



**AFT Fluorotec**  
Solutions and Components in Fluoropolymer Plastics

**Phone:** +44 (0) 1992 515880  
**Fax:** +44 (0) 1992 554490  
**Email:** [info@fluorotec.com](mailto:info@fluorotec.com)  
**Website:** [www.fluorotec.com](http://www.fluorotec.com)

Hertford Town Mill  
Tamworth Road  
Hertford  
Herts. SG13 7DJ